

# Wm. H. Brady, Inc.

P.O. Box 36  
Elkton, MD 21922-0036  
www.wmhbrady.com

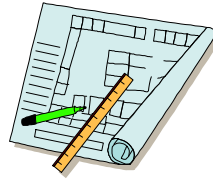

Phone: 410-398-4770  
Fax: 410-392-6165  
e-mail: [sales@wmhbrady.com](mailto:sales@wmhbrady.com)

<b>ROUND SPIRAL DUCT UNREINFORCED POSITIVE PRESSURE</b>			
<b>DIAMETER</b>	<b>2" POS.</b>	<b>4" POS.</b>	<b>10" POS.</b>
3 - 14"	26 GA	26 GA	26 GA
15 - 16"	26 GA	24 GA	24 GA
17 - 26"	26 GA	24 GA	24 GA
27 - 36"	24 GA	22 GA	22 GA
37 - 50"	22 GA	20 GA	20 GA
51 - 60"	20 GA	18 GA	18 GA
61 - 84"	18 GA	18 GA	18 GA

<b>RECOMMENDED METAL THICKNESS AND REINFORCEMENT FOR SINGLE WALL SPIRAL UNDER NEGATIVE PRESSURE W.G.</b>			
<b>DIAMETER</b>	<b>2" NEG.</b>	<b>3 - 4" NEG.</b>	<b>5 - 10" NEG.</b>
3 - 11"	26 GA	26 GA	26 GA
12 - 13"	26 GA	26 GA	24 GA
14"	26 GA	24 GA	24 GA
15 - 19"	24 GA	24 GA	22 GA
20 - 22"	24 GA	22 GA	22 GA
23 - 24"	22 GA	22 GA	20 GA
25 - 26"	22 GA	20 GA	20 GA
27 - 30"	22 GA	20 GA	18 GA
31 - 36"	20 GA	20 GA	18 GA
37 - 42"	20 GA	18 GA	18 GA A/R 12' ON CTR
43 - 48"	20 GA	18 GA	18 GA A/R 6' ON CTR
52 - 60"	18 GA	18 GA A/R 6' ON CTR	18 GA A/R 6' ON CTR

Schedule is for spiral duct only. In order to maintain the pressure class, all fittings will be fabricated from a metal gauge 2 gauges heavier than the adjoining spiral duct. Flange connections are considered as reinforcement.



Standard joint for spiral duct is slip connection. As alternatives, we offer the following connections:

Ductmate Spiralmate Flange  
Kirk and Blum Angle Rings  
Accuflange Round and Oval Dcut Connector  
Ward Industries Keating Coupling

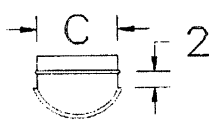
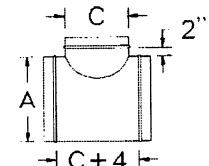
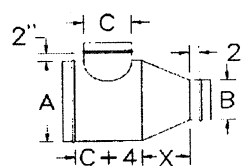
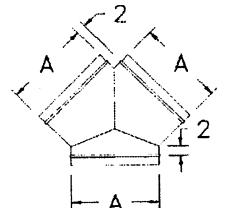
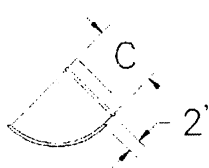
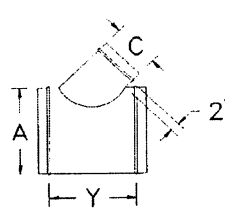
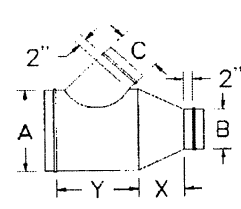
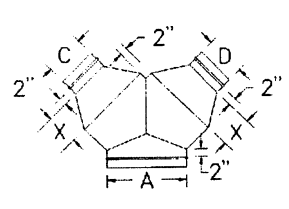
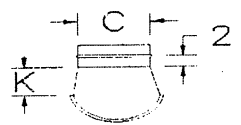
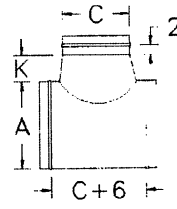
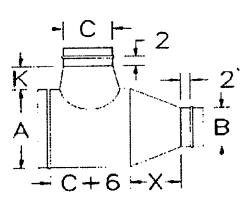
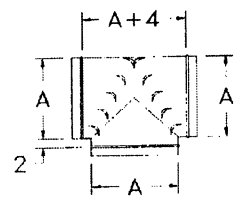
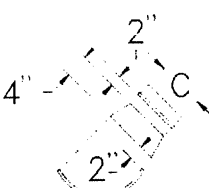
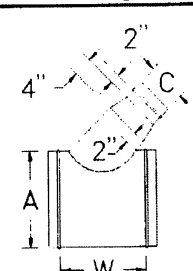
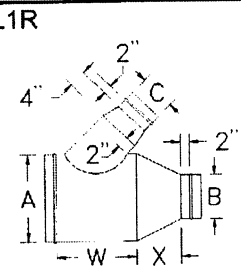
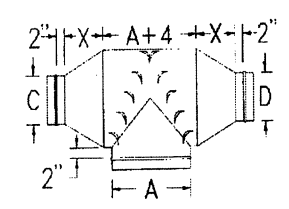
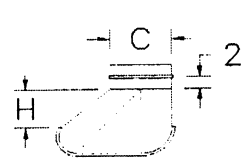
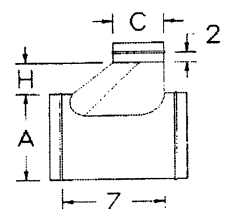
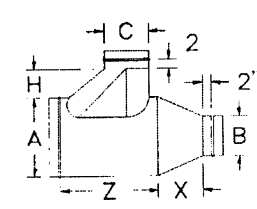
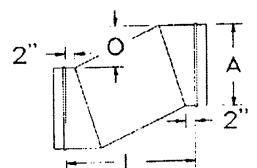
## Single Wall Round Spiral Pipe and Fitting Standards

<p>LT</p> 	<p>T1</p> 	<p>T1R</p> 	<p>Y2</p> 
<b>Straight 90 Degree Tees</b>			<b>"Y" Fittings</b>
<p>LL</p> 	<p>L1</p> 	<p>L1R</p> 	<p>Y2R</p> 
<b>45 Degree Laterals</b>			<b>Reducing "Y" Fittings</b>
<p>LCT</p> 	<p>CT1</p> 	<p>CT1R</p> 	<p>BT</p> 
<b>Conical 90 Degree Tees</b>			<b>Bullhead Tee</b>
<p>LCL</p> 	<p>CL1</p> 	<p>CL1R</p> 	<p>BTR</p> 
<b>Conical 45 Degree Lateral Tees</b>			<b>Reducing Bullhead</b>
<p>LLL</p> 	<p>LL1</p> 	<p>LL1R</p> 	<p>SET</p> 
<b>Low Loss 90 Degree Tees</b>			<b>Offset</b>

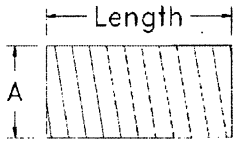
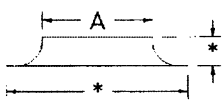
## Single Wall Round Spiral Pipe and Fitting Standards

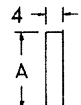
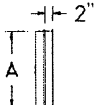
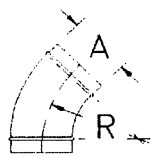
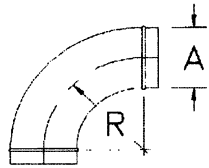
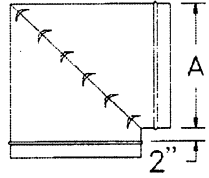
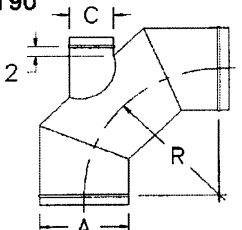
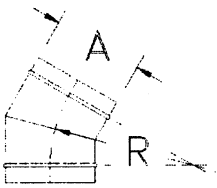
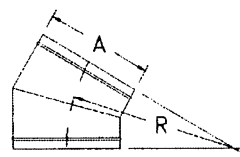
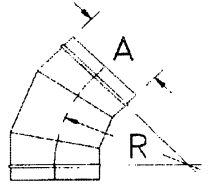
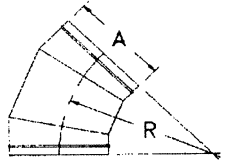
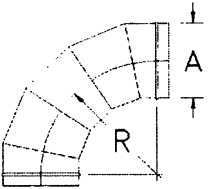
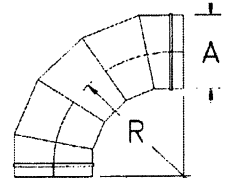
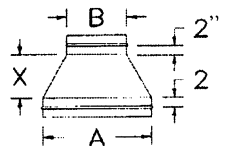
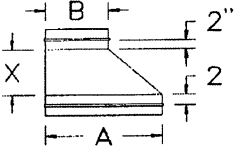
<p>SP</p> 	<p>B1</p> 	<p>PP</p>  <p>PIPE TO PIPE</p>	<p>FF</p>  <p>FITTING TO FITTING</p>	<p>EC</p>  <p>END CAP</p>	<p>EP</p>  <p>END PLUG</p>																								
<b>Spiral Pipe</b>	<b>Bellmouth</b>	<b>Couplings</b>		<b>Caps &amp; Plugs</b>																									
<p>SE45</p>  <p>A = 3" Thru 10"</p>	<p>SE90</p>  <p>A = 3" Thru 10"</p>	<p>EV90</p>  <p>A = 3" Thru 60"</p>	<p>ET90</p>  <p>A = 3" Thru 60"</p>																										
<b>Stamped Elbows</b>		<b>Mitered Elbow</b>	<b>Elbow w/ Tap</b>																										
<p>E1 Thru E36</p>  <p>A = 3" Thru 24"</p>	 <p>A = Greater than 24"</p>	<p>E37 Thru E71</p>  <p>A = 3" Thru 24"</p>	 <p>A = Greater than 24"</p>																										
<b>2 Gore Elbows</b>		<b>3 Gore Elbows</b>																											
<p>E72 Thru E90</p>  <p>A = 3" Thru 24"</p>	 <p>A = Greater than 24"</p>	<p>R1</p> 	<p>ER1</p> 																										
<b>5 Gore Elbows</b>		<b>Reducers</b>																											
<p><b>Dimensions:</b></p> <table style="width: 100%; border: none;"> <tr> <td style="width: 33%;">A = Inlet Size</td> <td style="width: 33%;">K = 5 1/4"</td> <td style="width: 33%;">V = (A/2x1.414)+((C+2)/2)+6</td> </tr> <tr> <td>B = Outlet Size</td> <td>L = Offset Length</td> <td>W = (C+2)x1.414+4</td> </tr> <tr> <td>C = Branch Size</td> <td>O = Offsetting Amount</td> <td>X = A - B (with 4" minimum)</td> </tr> <tr> <td>D = Branch Size</td> <td>R = 1.5 x A</td> <td>Y = (1.414xC) + 4</td> </tr> <tr> <td>H = 3" if C = 3" to 8"</td> <td>S = 2</td> <td>Z = C+H+4</td> </tr> <tr> <td>6" if C = 9" to 16"</td> <td>T = A/4+2</td> <td>* = Consult Factory</td> </tr> <tr> <td>9" if C = 17" to 24"</td> <td>U = Ax2+2</td> <td></td> </tr> <tr> <td>12" if C = 25" &amp; Up</td> <td></td> <td></td> </tr> </table>						A = Inlet Size	K = 5 1/4"	V = (A/2x1.414)+((C+2)/2)+6	B = Outlet Size	L = Offset Length	W = (C+2)x1.414+4	C = Branch Size	O = Offsetting Amount	X = A - B (with 4" minimum)	D = Branch Size	R = 1.5 x A	Y = (1.414xC) + 4	H = 3" if C = 3" to 8"	S = 2	Z = C+H+4	6" if C = 9" to 16"	T = A/4+2	* = Consult Factory	9" if C = 17" to 24"	U = Ax2+2		12" if C = 25" & Up		
A = Inlet Size	K = 5 1/4"	V = (A/2x1.414)+((C+2)/2)+6																											
B = Outlet Size	L = Offset Length	W = (C+2)x1.414+4																											
C = Branch Size	O = Offsetting Amount	X = A - B (with 4" minimum)																											
D = Branch Size	R = 1.5 x A	Y = (1.414xC) + 4																											
H = 3" if C = 3" to 8"	S = 2	Z = C+H+4																											
6" if C = 9" to 16"	T = A/4+2	* = Consult Factory																											
9" if C = 17" to 24"	U = Ax2+2																												
12" if C = 25" & Up																													